

SPECTRE™



DESCRIPTION

- Spectre advanced timber fixing screws
- Multi-layer Ruspert coating, salt spray tested to 1000 hours
- 8mm hex/flange head
- Reamer to prevent jacking
- Quick start Type 17 slash point
- Under head ribs
- 60° deep single thread
- Synthetic lubrication
- Surface hardened

APPLICATIONS

- For exterior use, widely used in timber, fencing and landscaping applications

CE APPROVED



- Tested to European inspection and certification standards EN 14592:2008+A1:2012

FOR EXTERIOR USE

ANTI CORROSION COATING

Multi-layer Ruspert® 1000 Hour Salt Spray Tested

PRODUCT OVERVIEW

Code	Diameter (mm)	Length (mm)	Head	Finish	Box Qty
SPETF65G	6.3	65	Hex/Flange	Green • Multi-layer Ruspert	50
SPETF87G	6.3	87	Hex/Flange	Green • Multi-layer Ruspert	50
SPETF100G	6.3	100	Hex/Flange	Green • Multi-layer Ruspert	50
SPETF150G	6.3	150	Hex/Flange	Green • Multi-layer Ruspert	50
SPETF200G	6.3	200	Hex/Flange	Green • Multi-layer Ruspert	50
SPETF250G	6.3	250	Hex/Flange	Green • Multi-layer Ruspert	50

TECHNICAL INFORMATION

Size (mm)	Imperial Size	Socket Size	Thread Length	Torque	Torsional Ratio	Tensile Strength
6.3 x 65	1/4" x 2 1/2"	8.0mm	53mm	160Kg-cm Min.	5.34	19.02kN
6.3 x 87	1/4" x 3 1/2"	8.0mm	53mm	160Kg-cm Min.	5.34	19.02kN
6.3 x 100	1/4" x 4"	8.0mm	53mm	160Kg-cm Min.	5.34	19.02kN
6.3 x 150	1/4" x 6"	8.0mm	53mm	160Kg-cm Min.	5.34	19.02kN
6.3 x 200	1/4" x 8"	8.0mm	53mm	160Kg-cm Min.	5.34	19.02kN
6.3 x 250	1/4" x 10"	8.0mm	53mm	160Kg-cm Min.	5.34	19.02kN

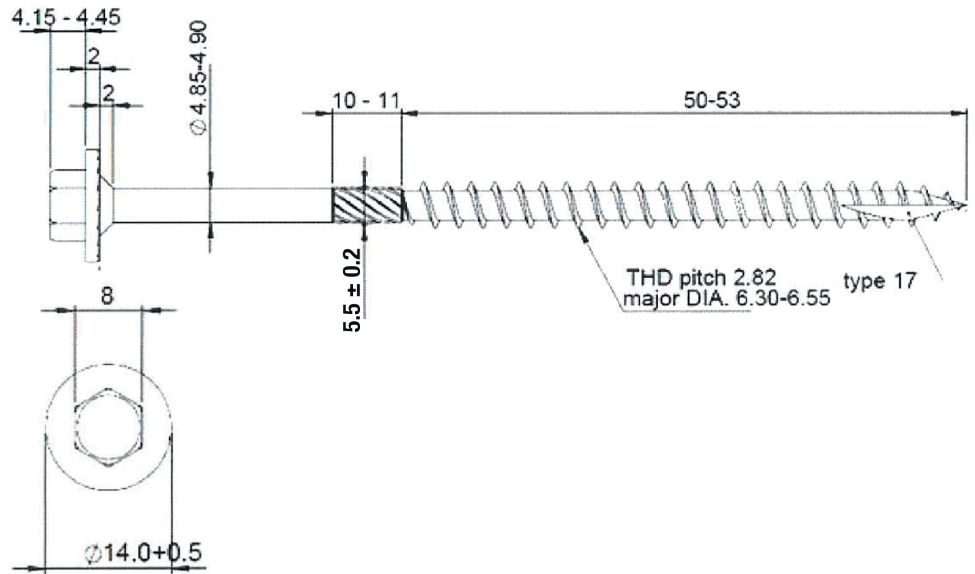

- **Material:** C1022

- **Surface Hardness:** 500 HV Min.

- **Core Hardness:** 280 HV Min.

